

PROPRIETARY AND CONFIDENTIAL
 THE INFORMATION CONTAINED IN THIS DRAWING IS THE SOLE PROPERTY OF <INSERT COMPANY NAME HERE>. ANY REPRODUCTION IN PART OR AS A WHOLE WITHOUT THE WRITTEN PERMISSION OF <INSERT COMPANY NAME HERE> IS PROHIBITED.

		UNLESS OTHERWISE SPECIFIED:		NAME	DATE	TITLE: DC POWER SUPPLY					
		DIMENSIONS ARE IN INCHES	DRAWN	Lim	03/14				SIZE A DWG. NO. A01.00 REV SCALE: 1:4 WEIGHT: SHEET 1 OF 10		
		TOLERANCES:	CHECKED								
		FRACTIONAL ±	ENG APPR.								
		ANGULAR: MACH ± BEND ±	MFG APPR.								
		TWO PLACE DECIMAL ±	Q.A.								
		THREE PLACE DECIMAL ±	COMMENTS:								
		INTERPRET GEOMETRIC TOLERANCING PER:									
		MATERIAL									
		FINISH									
NEXT ASSY	USED ON										
APPLICATION		DO NOT SCALE DRAWING									

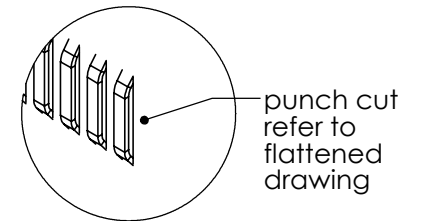
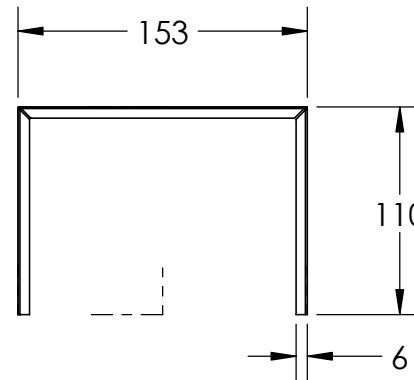
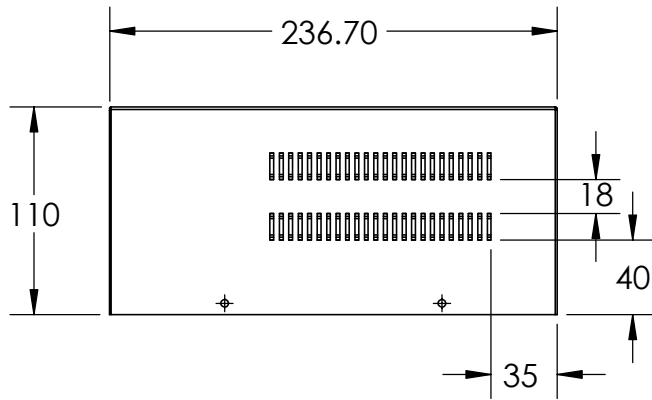
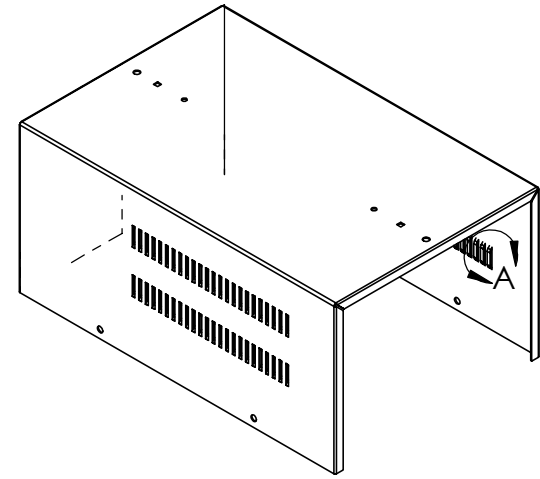
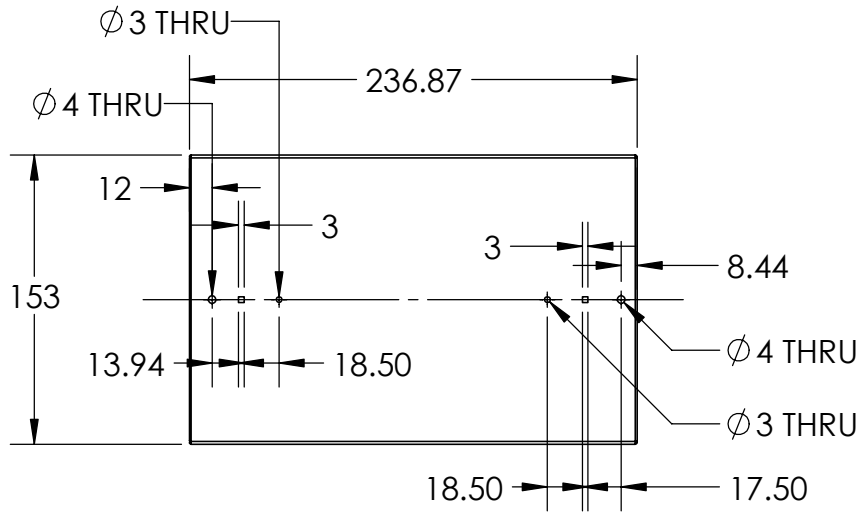

DETAIL A
SCALE 1 : 1

PROPRIETARY AND CONFIDENTIAL
THE INFORMATION CONTAINED IN THIS DRAWING IS THE SOLE PROPERTY OF <INSERT COMPANY NAME HERE>. ANY REPRODUCTION IN PART OR AS A WHOLE WITHOUT THE WRITTEN PERMISSION OF <INSERT COMPANY NAME HERE> IS PROHIBITED.

		UNLESS OTHERWISE SPECIFIED:		NAME	DATE	TITLE: PART NO.1 DETAILS														
		DIMENSIONS ARE IN INCHES TOLERANCES: FRACTIONAL ± ANGULAR: MACH ± BEND ± TWO PLACE DECIMAL ± THREE PLACE DECIMAL ±	DRAWN	Lim	03/14				<table border="1"> <tr> <td>SIZE</td> <td>DWG. NO.</td> <td>REV</td> </tr> <tr> <td>A</td> <td>A01.01</td> <td></td> </tr> <tr> <td>SCALE: 1:4</td> <td>WEIGHT:</td> <td>SHEET 2 OF 10</td> </tr> </table>			SIZE	DWG. NO.	REV	A	A01.01		SCALE: 1:4	WEIGHT:	SHEET 2 OF 10
SIZE	DWG. NO.	REV																		
A	A01.01																			
SCALE: 1:4	WEIGHT:	SHEET 2 OF 10																		
		INTERPRET GEOMETRIC TOLERANCING PER:	CHECKED			<table border="1"> <tr> <td>ENG APPR.</td> <td></td> <td></td> </tr> <tr> <td>MFG APPR.</td> <td></td> <td></td> </tr> <tr> <td>Q.A.</td> <td></td> <td></td> </tr> </table>			ENG APPR.			MFG APPR.			Q.A.					
ENG APPR.																				
MFG APPR.																				
Q.A.																				
		MATERIAL	COMMENTS:																	
NEXT ASSY	USED ON	FINISH																		
APPLICATION		DO NOT SCALE DRAWING																		

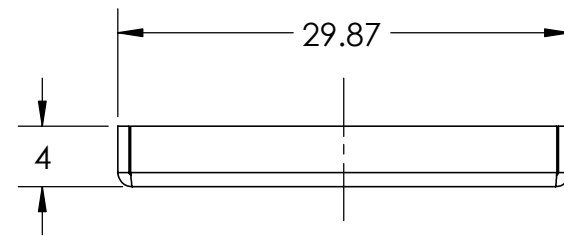
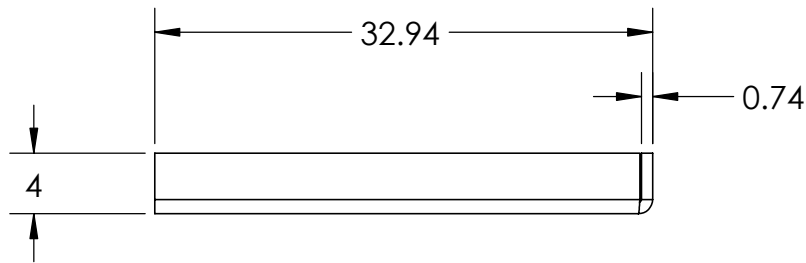
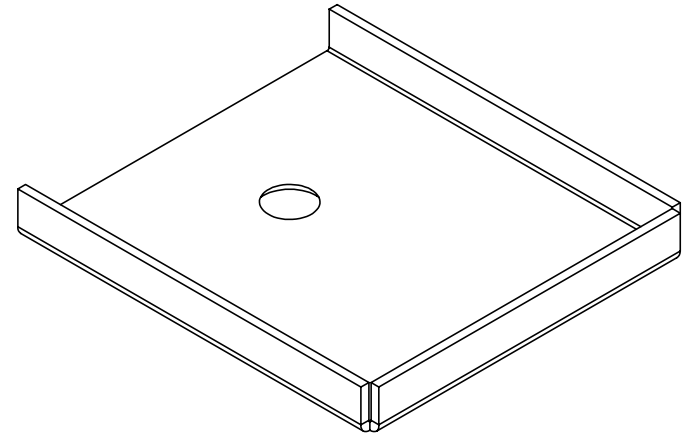
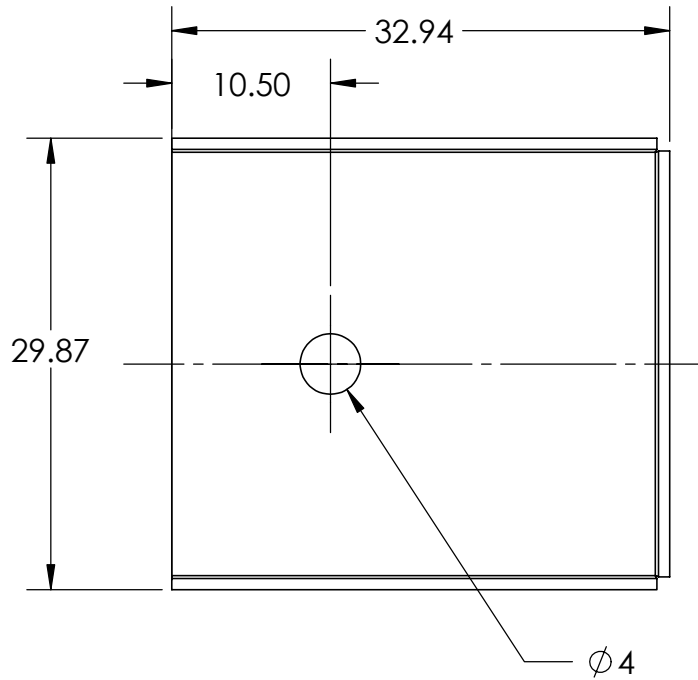

PROPRIETARY AND CONFIDENTIAL
 THE INFORMATION CONTAINED IN THIS DRAWING IS THE SOLE PROPERTY OF <INSERT COMPANY NAME HERE>. ANY REPRODUCTION IN PART OR AS A WHOLE WITHOUT THE WRITTEN PERMISSION OF <INSERT COMPANY NAME HERE> IS PROHIBITED.

		UNLESS OTHERWISE SPECIFIED:		NAME	DATE	TITLE: PART NO.2 DETAILS					
		DIMENSIONS ARE IN INCHES	DRAWN	Lim	03/14				SIZE A DWG. NO. A01.02 REV SCALE: 2:1 WEIGHT: SHEET 3 OF 10		
		TOLERANCES: FRACTIONAL ±	CHECKED								
		ANGULAR: MACH ± BEND ±	ENG APPR.								
		TWO PLACE DECIMAL ± THREE PLACE DECIMAL ±	MFG APPR.								
		INTERPRET GEOMETRIC TOLERANCING PER:	Q.A.								
		MATERIAL	COMMENTS:								
NEXT ASSY	USED ON	FINISH									
APPLICATION		DO NOT SCALE DRAWING									

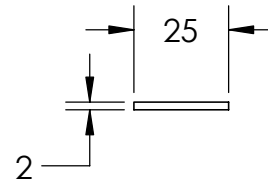
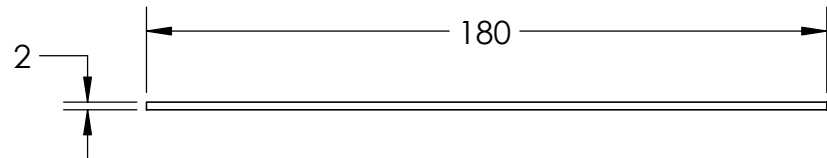
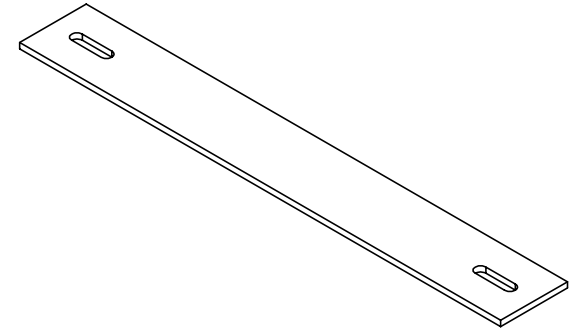
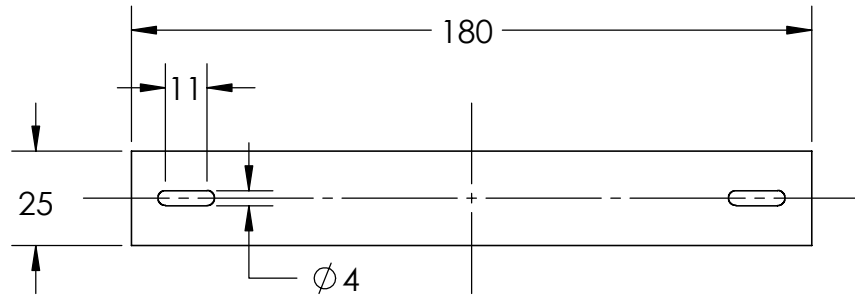

PROPRIETARY AND CONFIDENTIAL
 THE INFORMATION CONTAINED IN THIS DRAWING IS THE SOLE PROPERTY OF <INSERT COMPANY NAME HERE>. ANY REPRODUCTION IN PART OR AS A WHOLE WITHOUT THE WRITTEN PERMISSION OF <INSERT COMPANY NAME HERE> IS PROHIBITED.

		UNLESS OTHERWISE SPECIFIED:		NAME	DATE			
		DIMENSIONS ARE IN INCHES	DRAWN	Lim	03/14	TITLE: PART NO.3 DETAILS		
		TOLERANCES:	CHECKED					
		FRACTIONAL ±	ENG APPR.					
		ANGULAR: MACH ± BEND ±	MFG APPR.					
		TWO PLACE DECIMAL ±	Q.A.			SIZE	DWG. NO.	REV
		THREE PLACE DECIMAL ±	COMMENTS:			A	A01.03	
		INTERPRET GEOMETRIC TOLERANCING PER:				SCALE: 1:2	WEIGHT:	SHEET 4 OF 10
		MATERIAL						
NEXT ASSY	USED ON	FINISH						
APPLICATION		DO NOT SCALE DRAWING						

5

4

3

2

1

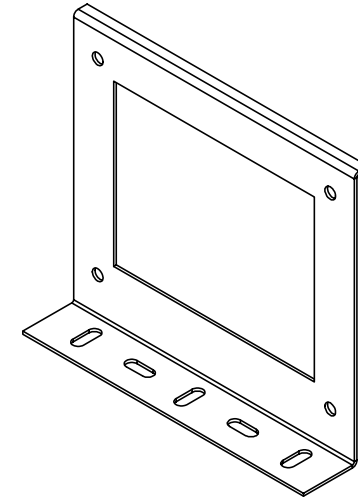
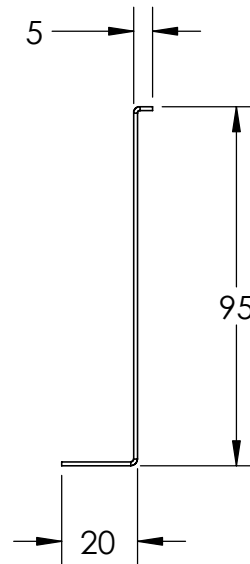
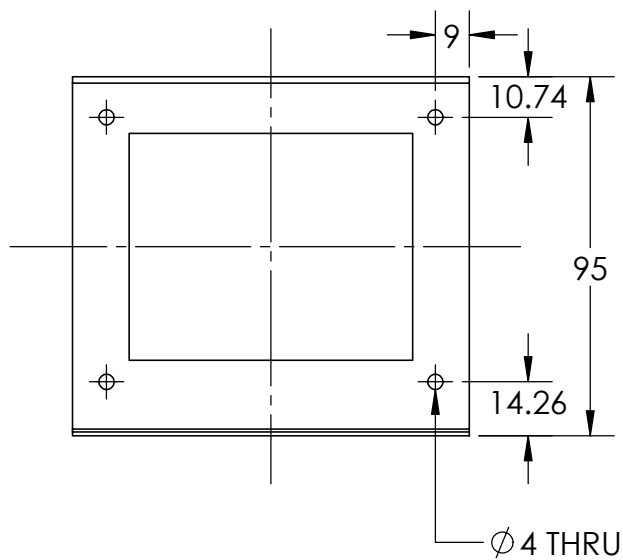
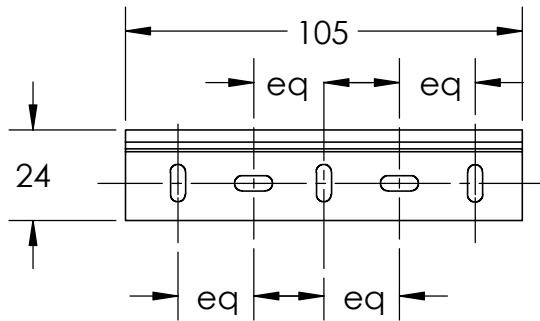

PROPRIETARY AND CONFIDENTIAL
 THE INFORMATION CONTAINED IN THIS DRAWING IS THE SOLE PROPERTY OF <INSERT COMPANY NAME HERE>. ANY REPRODUCTION IN PART OR AS A WHOLE WITHOUT THE WRITTEN PERMISSION OF <INSERT COMPANY NAME HERE> IS PROHIBITED.

		UNLESS OTHERWISE SPECIFIED:		NAME	DATE
		DIMENSIONS ARE IN INCHES	DRAWN	Lim	03/14
		TOLERANCES:	CHECKED		
		FRACTIONAL ±	ENG APPR.		
		ANGULAR: MACH ± BEND ±	MFG APPR.		
		TWO PLACE DECIMAL ±	Q.A.		
		THREE PLACE DECIMAL ±	COMMENTS:		
		INTERPRET GEOMETRIC TOLERANCING PER:			
		MATERIAL			
NEXT ASSY	USED ON	FINISH			
APPLICATION		DO NOT SCALE DRAWING			

TITLE:		
PART NO.4 DETAILS		
SIZE	DWG. NO.	REV
A	A01.04	
SCALE: 1:2	WEIGHT:	SHEET 5 OF 10

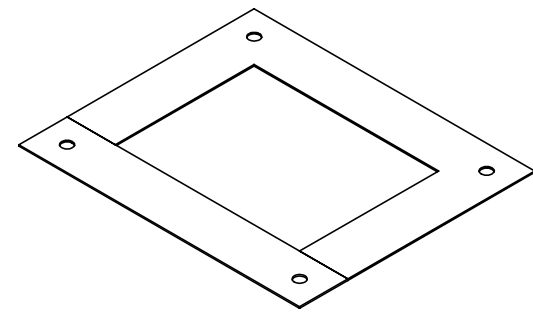
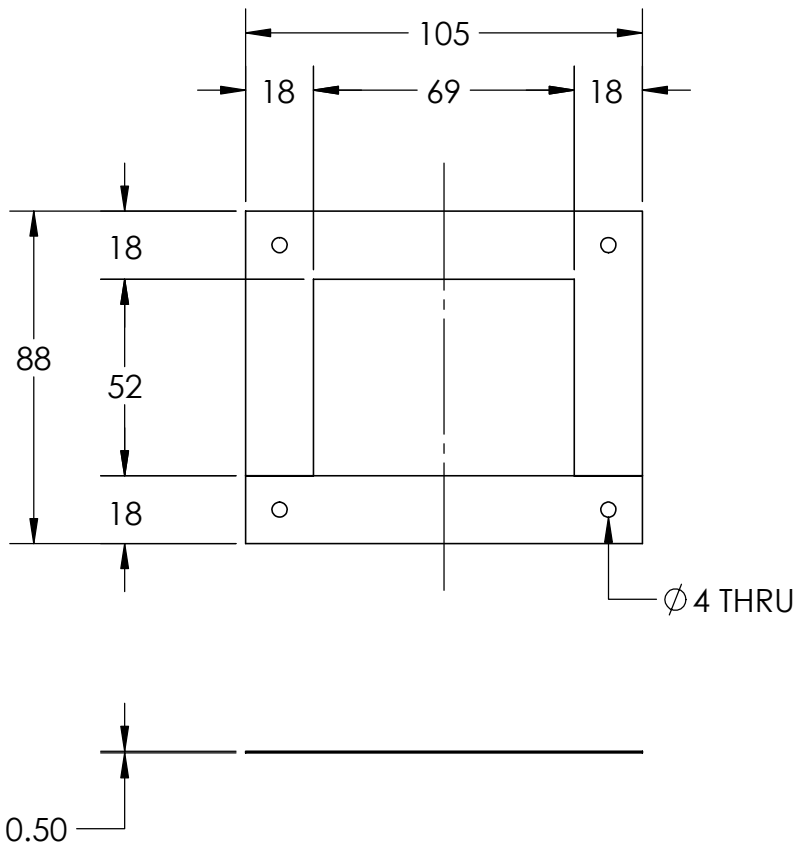

PROPRIETARY AND CONFIDENTIAL
 THE INFORMATION CONTAINED IN THIS DRAWING IS THE SOLE PROPERTY OF <INSERT COMPANY NAME HERE>. ANY REPRODUCTION IN PART OR AS A WHOLE WITHOUT THE WRITTEN PERMISSION OF <INSERT COMPANY NAME HERE> IS PROHIBITED.

		UNLESS OTHERWISE SPECIFIED:		NAME	DATE	TITLE: PART NO.5 DETAILS														
		DIMENSIONS ARE IN INCHES TOLERANCES: FRACTIONAL ± ANGULAR: MACH ± BEND ± TWO PLACE DECIMAL ± THREE PLACE DECIMAL ±	DRAWN	Lim	03/14				<table border="1"> <tr> <td>SIZE</td> <td>DWG. NO.</td> <td>REV</td> </tr> <tr> <td>A</td> <td>A01.05</td> <td></td> </tr> <tr> <td>SCALE: 1:2</td> <td>WEIGHT:</td> <td>SHEET 6 OF 10</td> </tr> </table>			SIZE	DWG. NO.	REV	A	A01.05		SCALE: 1:2	WEIGHT:	SHEET 6 OF 10
SIZE	DWG. NO.	REV																		
A	A01.05																			
SCALE: 1:2	WEIGHT:	SHEET 6 OF 10																		
		INTERPRET GEOMETRIC TOLERANCING PER:	CHECKED			<table border="1"> <tr> <td>Q.A.</td> <td></td> <td></td> </tr> <tr> <td colspan="3">COMMENTS:</td> </tr> </table>			Q.A.			COMMENTS:								
Q.A.																				
COMMENTS:																				
		MATERIAL	MFG APPR.			<table border="1"> <tr> <td>Q.A.</td> <td></td> <td></td> </tr> <tr> <td colspan="3">COMMENTS:</td> </tr> </table>			Q.A.			COMMENTS:								
Q.A.																				
COMMENTS:																				
NEXT ASSY	USED ON	FINISH				<table border="1"> <tr> <td>Q.A.</td> <td></td> <td></td> </tr> <tr> <td colspan="3">COMMENTS:</td> </tr> </table>			Q.A.			COMMENTS:								
Q.A.																				
COMMENTS:																				
APPLICATION		DO NOT SCALE DRAWING				<table border="1"> <tr> <td>Q.A.</td> <td></td> <td></td> </tr> <tr> <td colspan="3">COMMENTS:</td> </tr> </table>			Q.A.			COMMENTS:								
Q.A.																				
COMMENTS:																				

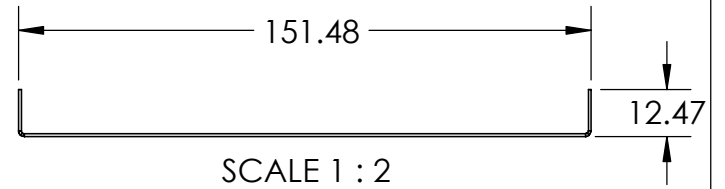
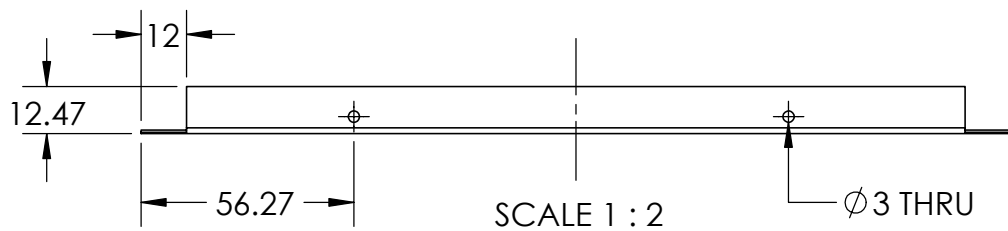
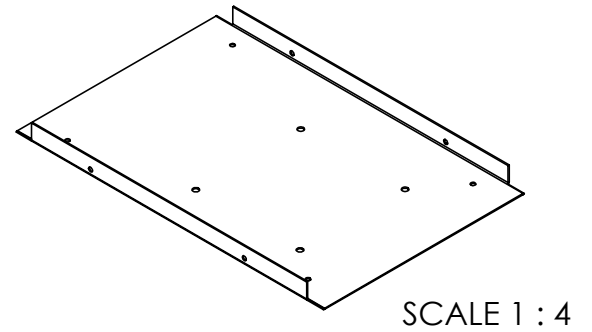
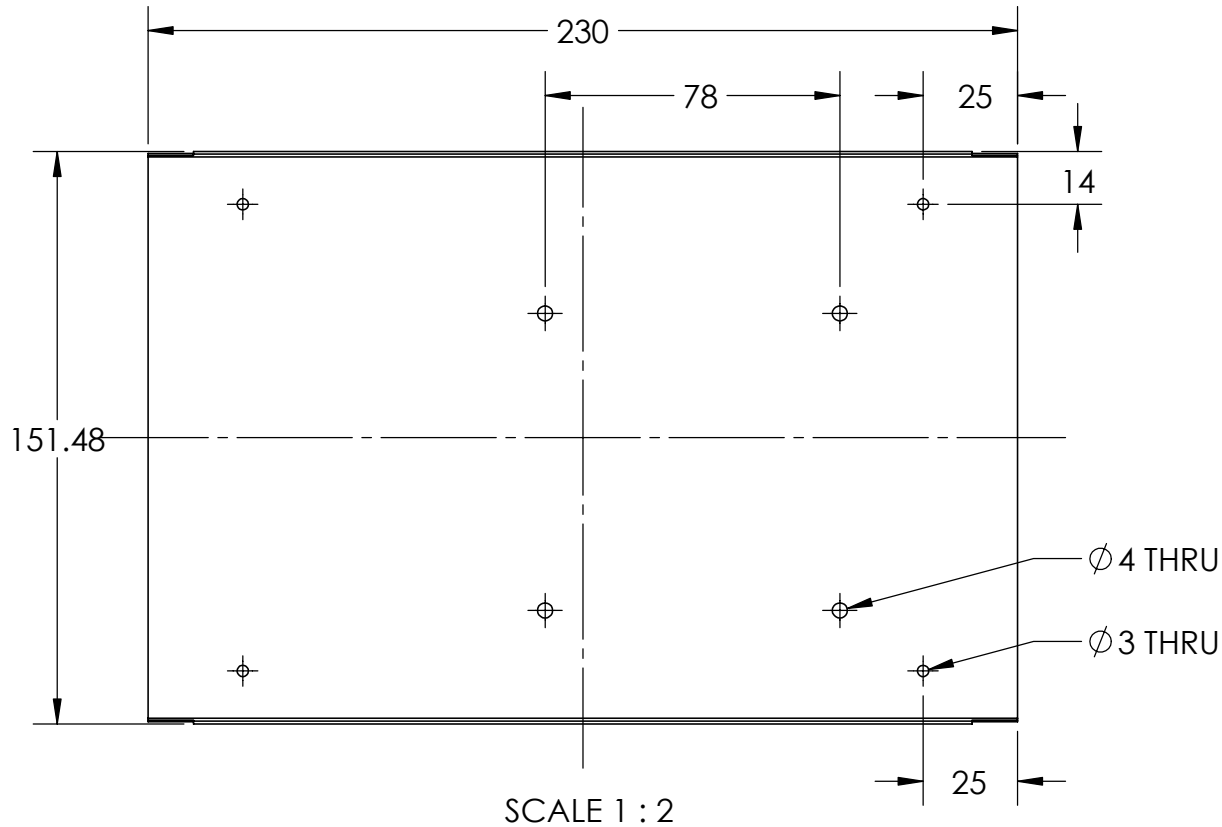

PROPRIETARY AND CONFIDENTIAL
 THE INFORMATION CONTAINED IN THIS DRAWING IS THE SOLE PROPERTY OF <INSERT COMPANY NAME HERE>. ANY REPRODUCTION IN PART OR AS A WHOLE WITHOUT THE WRITTEN PERMISSION OF <INSERT COMPANY NAME HERE> IS PROHIBITED.

		UNLESS OTHERWISE SPECIFIED:		NAME	DATE	TITLE: PART NO.6 DETAILS					
		DIMENSIONS ARE IN INCHES	DRAWN	Lim	03/14				SIZE A DWG. NO. A01.06 REV as shown WEIGHT: SHEET 7 OF 10		
		TOLERANCES:	CHECKED								
		FRACTIONAL ±	ENG APPR.								
		ANGULAR: MACH ± BEND ±	MFG APPR.								
		TWO PLACE DECIMAL ±	Q.A.								
		THREE PLACE DECIMAL ±	COMMENTS:								
		INTERPRET GEOMETRIC TOLERANCING PER:									
		MATERIAL									
NEXT ASSY	USED ON	FINISH									
APPLICATION		DO NOT SCALE DRAWING									

5

4

3

2

1

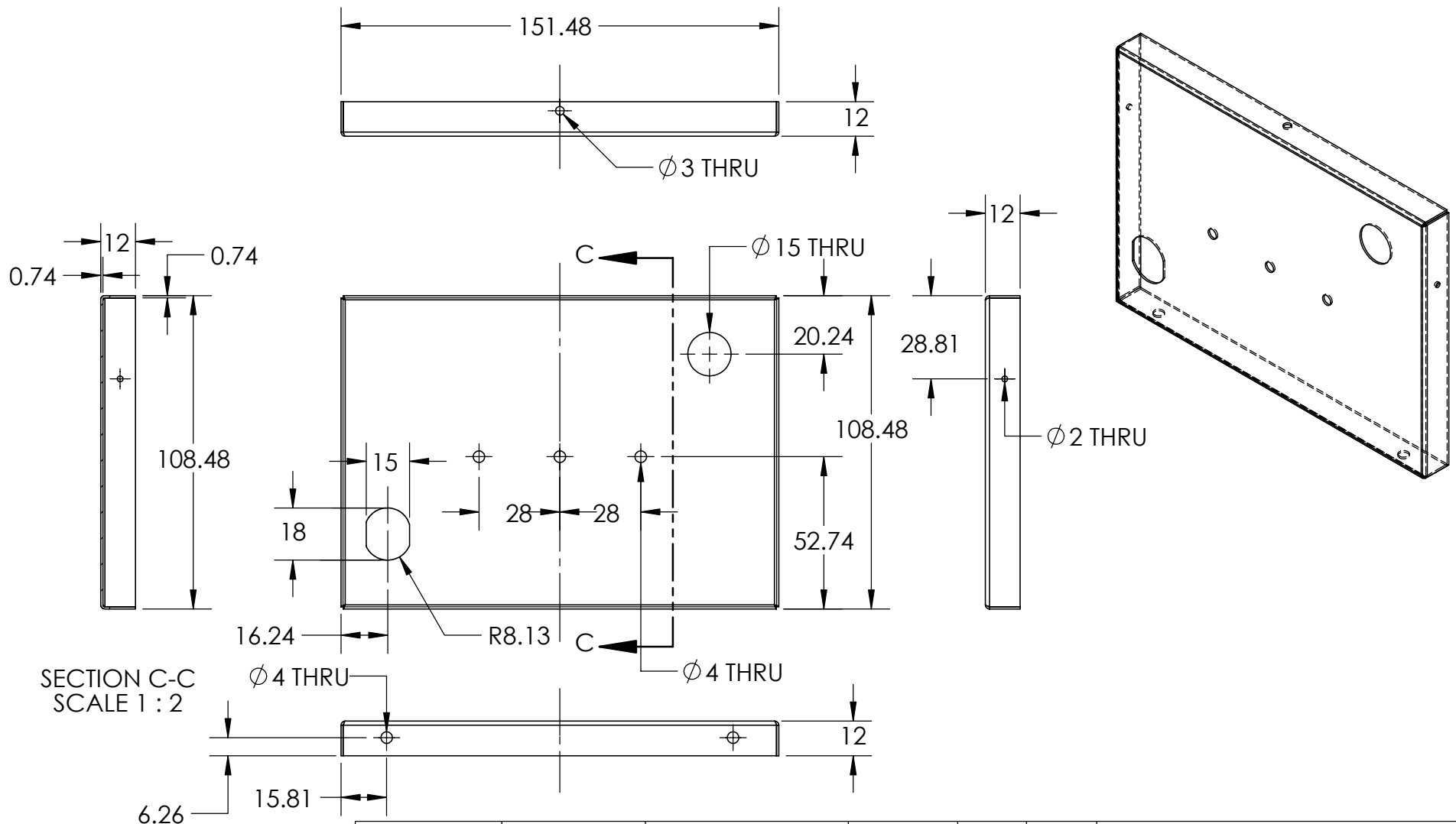

SECTION C-C
SCALE 1 : 2

PROPRIETARY AND CONFIDENTIAL
THE INFORMATION CONTAINED IN THIS DRAWING IS THE SOLE PROPERTY OF <INSERT COMPANY NAME HERE>. ANY REPRODUCTION IN PART OR AS A WHOLE WITHOUT THE WRITTEN PERMISSION OF <INSERT COMPANY NAME HERE> IS PROHIBITED.

		UNLESS OTHERWISE SPECIFIED:		NAME	DATE	TITLE: PART NO. 8 DETAILS														
		DIMENSIONS ARE IN INCHES	DRAWN	Lim	03/14				<table border="1"> <tr> <td>SIZE</td> <td>DWG. NO.</td> <td>REV</td> </tr> <tr> <td>A</td> <td>A01.08</td> <td></td> </tr> <tr> <td>SCALE:: 1:2</td> <td>WEIGHT:</td> <td>SHEET 9 OF 10</td> </tr> </table>			SIZE	DWG. NO.	REV	A	A01.08		SCALE:: 1:2	WEIGHT:	SHEET 9 OF 10
SIZE	DWG. NO.	REV																		
A	A01.08																			
SCALE:: 1:2	WEIGHT:	SHEET 9 OF 10																		
		TOLERANCES:	CHECKED			COMMENTS:														
		FRACTIONAL ±	ENG APPR.																	
		ANGULAR: MACH ± BEND ±	MFG APPR.																	
		TWO PLACE DECIMAL ±	Q.A.																	
		THREE PLACE DECIMAL ±																		
		INTERPRET GEOMETRIC TOLERANCING PER:																		
		MATERIAL																		
		FINISH																		
NEXT ASSY	USED ON																			
APPLICATION		DO NOT SCALE DRAWING																		

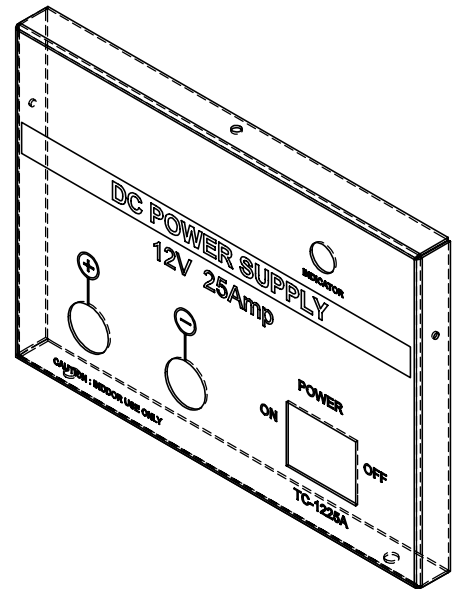
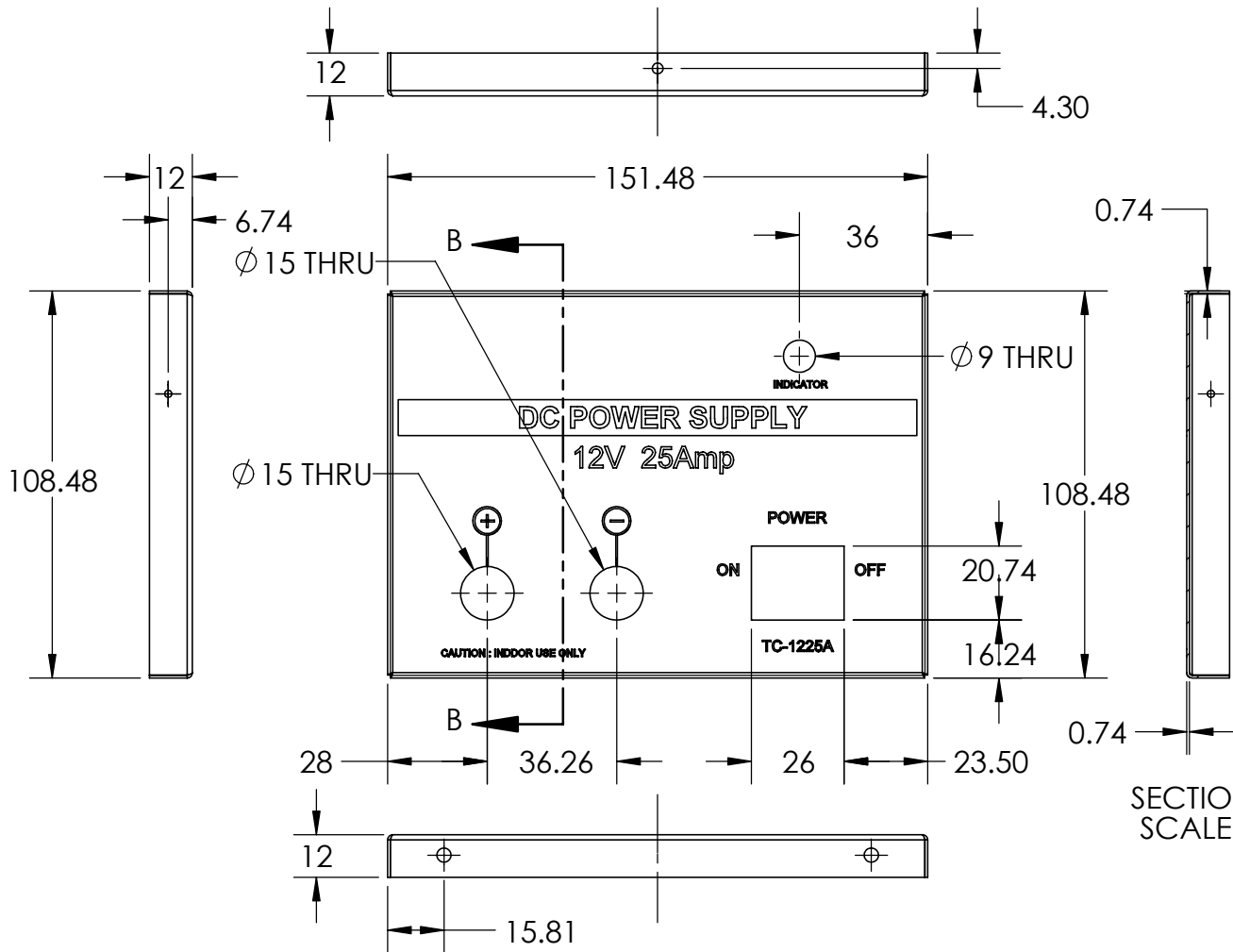

SECTION B-B
SCALE 1 : 2

PROPRIETARY AND CONFIDENTIAL
THE INFORMATION CONTAINED IN THIS DRAWING IS THE SOLE PROPERTY OF <INSERT COMPANY NAME HERE>. ANY REPRODUCTION IN PART OR AS A WHOLE WITHOUT THE WRITTEN PERMISSION OF <INSERT COMPANY NAME HERE> IS PROHIBITED.

		UNLESS OTHERWISE SPECIFIED:		NAME	DATE
		DIMENSIONS ARE IN INCHES	DRAWN	Lim	03/14
		TOLERANCES:	CHECKED		
		FRACTIONAL \pm	ENG APPR.		
		ANGULAR: MACH \pm BEND \pm	MFG APPR.		
		TWO PLACE DECIMAL \pm	Q.A.		
		THREE PLACE DECIMAL \pm	COMMENTS:		
		INTERPRET GEOMETRIC TOLERANCING PER:			
		MATERIAL			
NEXT ASSY	USED ON	FINISH			
APPLICATION		DO NOT SCALE DRAWING			

TITLE:		
PART NO.9 DETAILS		
SIZE	DWG. NO.	REV
A	A01.09	
SCALE: 1:2	WEIGHT:	SHEET 10 OF 10